



# NEXCOM International Co. Ltd.(8234)

---

## 2024/Q3 Investor Conference

# Disclaimer

---

This presentation may contain forward-looking information based on current assumptions and evaluations. The actual result in the future may differ from these forward-looking information materially, subject to uncertainties and risks that we could not control. Nexcom is not obliged to update any information mentioned above. And we are not responsible to any loss occurred by citing or using the information of this presentation.

# Outline

---

- Overview
- Financial Results
- Others



# Overview

# General Information

---

- Established by chairman Mr. Clement Lin in 1992
- Listed in Teipei Exchange in 2007 (Stock Code:8234)
- Capital is about NTD \$1.412 billion
- Market value is about NTD \$7billion (share price of 11/12 is \$49.65)
- Employees all over the world: 1,220(at the end of 3<sup>rd</sup> quarter)
- One of the leading company domain in industrial computer

# Major Business



**Network & Communication**



**IoT Automation**



**Smart City**



**Mobile Computing**



**Intelligent Video Surveillance**

other developing business

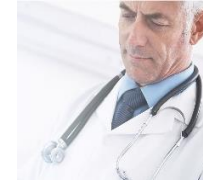

**Medical & Healthcare**



**IoT Security Solution**



**AIoT Cloud**

# Major Operating Units

---

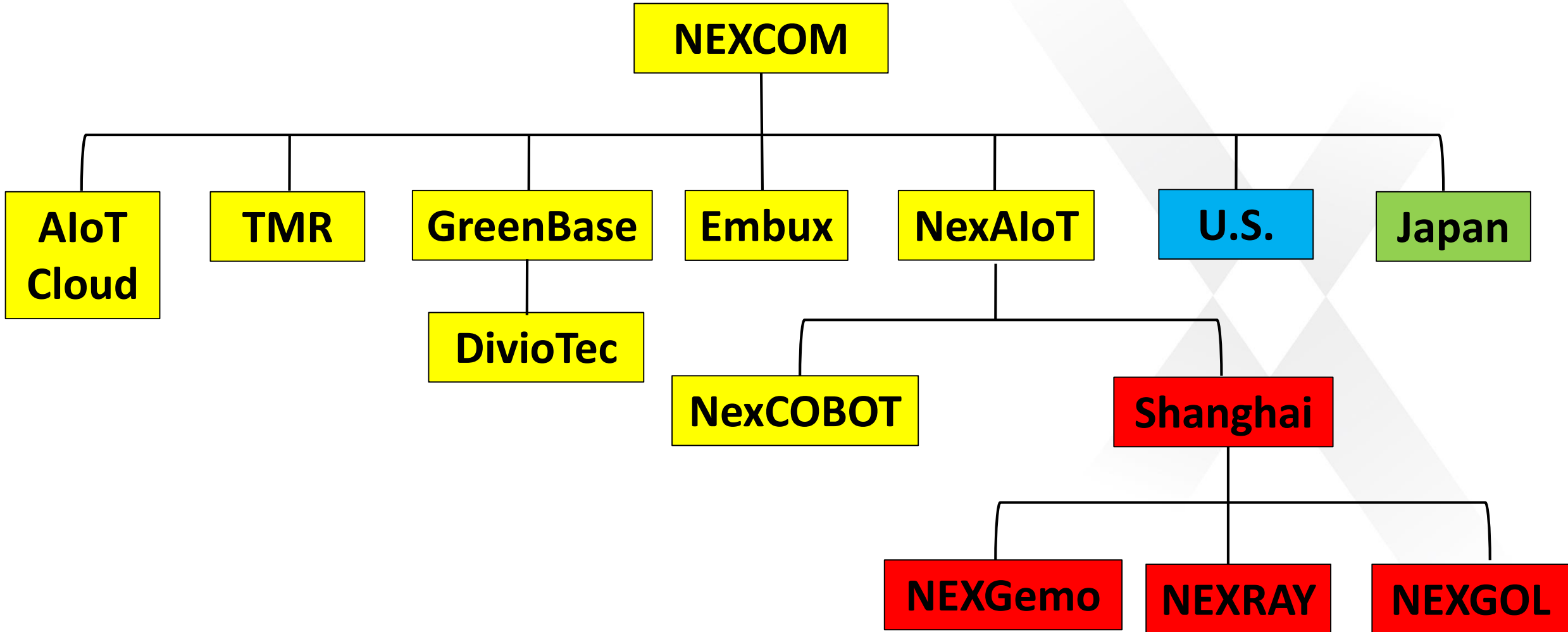

# Contribution of Major Business

---

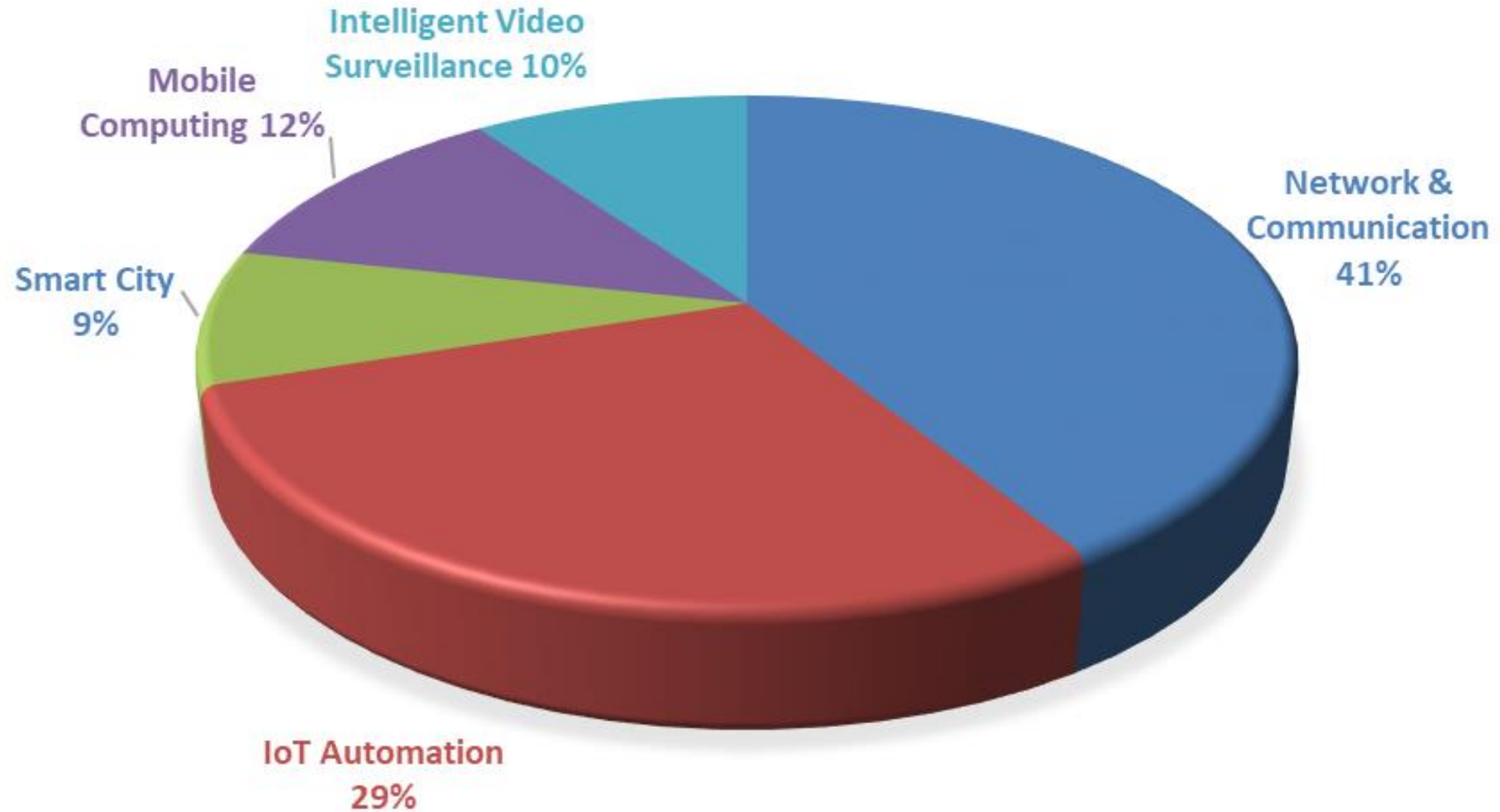



# Financial Results

# Income Statement

NTD ,000	2024/Q3	2024/Q2	2024/Q1	2024/Q1~3	2023/Q1~3	QOQ	YOY
Sales	1,501,418	1,161,066	1,164,778	3,827,262	4,522,936	29.31%	-15.38%
Costs	1,110,594	882,473	909,636	2,902,703	3,212,443	25.85%	-9.64%
Gross Margin	390,824	278,593	255,142	924,559	1,310,493	40.28%	-29.45%
Margin Rate	26.03%	23.99%	21.90%	24.16%	28.97%	8.48%	-16.63%
Selling Exp.	167,813	173,107	157,579	498,499	508,504	-3.06%	-1.97%
Admin. Exp.	37,478	40,457	37,795	115,730	100,340	-7.36%	15.34%
R & D Exp.	152,003	152,297	146,366	450,666	435,684	-0.19%	3.44%
Credit Impairment Loss	26,168	3,531	4,079	33,778	(16,534)	641.09%	-304.29%
Total Exp.	383,462	369,392	345,819	1,098,673	1,027,994	3.81%	6.88%
Operating Profit	7,362	(90,799)	(90,677)	(174,114)	282,499	-108.11%	-161.63%
Non-operating Items	4,365	34,753	71,051	110,169	47,196	-87.44%	133.43%
Income before Tax	11,727	(56,046)	(19,626)	(63,945)	329,695	-120.92%	-119.40%
Tax	(3,719)	59,356	(1,444)	54,193	(74,041)	-106.27%	-173.19%
Net Income	8,008	3,310	(21,070)	(9,752)	255,654	141.93%	-103.81%
Profit Attributable to Owner of Parent	25,447	10,642	(20,072)	16,017	226,895	139.12%	-92.94%
EPS	0.18	0.08	(0.14)	0.11	1.61	125.00%	-93.17%

# Balance Sheet - Assets

NTD ,000	2024/9/30	2024/6/30	2023/9/30	QOQ	YOY
Cash	1,391,158	1,617,438	1,760,102	-14%	-21%
Accounts Receivable	1,152,245	944,701	1,330,520	22%	-13%
Other Receivable	78,157	60,177	297,106	30%	-74%
Inventories	1,556,023	1,616,531	1,917,272	-4%	-19%
Other Current Assets	85,555	84,836	60,529	1%	41%
<b>Current Assets</b>	<b>4,263,138</b>	<b>4,323,683</b>	<b>5,365,529</b>	<b>-1%</b>	<b>-21%</b>
Financial Assets/Equity Investment	54,861	68,686	76,284	-20%	-28%
Fixed / Right-of-use Assets	1,758,271	1,730,354	1,813,029	2%	-3%
Investment Property	169,895	170,275	171,415	0%	-1%
Other Assets	232,031	234,040	195,028	-1%	19%
<b>Total Assets</b>	<b>6,478,196</b>	<b>6,527,038</b>	<b>7,621,285</b>	<b>-1%</b>	<b>-15%</b>

# Balance Sheet – Liabilities & Equities

NTD ,000	2024/9/30	2024/6/30	2023/9/30	QOQ	YOY
Short-term Bank Loan	1,341,500	1,384,600	1,805,000	-3%	-26%
Accounts Payable	760,563	735,316	619,578	3%	23%
Other Payable	505,489	530,661	892,802	-5%	-43%
Other Current Lia.	281,508	295,121	335,861	-5%	-16%
<b>Current Lia.</b>	<b>2,889,060</b>	<b>2,945,698</b>	<b>3,653,241</b>	<b>-2%</b>	<b>-21%</b>
Other Lia.	441,391	423,665	538,423	4%	-18%
<b>Total Liabilities</b>	<b>3,330,451</b>	<b>3,369,363</b>	<b>4,191,664</b>	<b>-1%</b>	<b>-21%</b>
Common Stock	1,412,265	1,412,265	1,412,265	0%	0%
Capital Surplus	375,545	368,397	366,535	2%	2%
Legal/Special Reserve	467,035	467,035	458,496	0%	2%
Retained Earnings	828,440	802,993	1,035,819	3%	-20%
Other Equities	(6,123)	20,367	30,164	-130%	-120%
Non-controlling Interest	70,583	86,618	126,342	-19%	-44%
<b>Total Equities</b>	<b>3,147,745</b>	<b>3,157,675</b>	<b>3,429,621</b>	<b>0%</b>	<b>-8%</b>

# Key Financial Ratio

---

	2024/Q3	2023
AR Turnover Days	81	97
Inventory Turnover Days	199	217
Current Ratio	1.48	1.48
Quick Ratio	0.91	0.91
Debt Ratio	0.51	0.52

Others

# Others

---

- The performance of Q3 is better than Q2 and Q1.
- GBT is ready to go IPO.

THANK YOU



Q & A