



NEXCOM International Co., Ltd.

Intelligent Platform & Services Business Unit
Wide Screen Touch Computer
XPPC 24-10N97A
User Manual

CONTENTS

Preface

Copyright	iv
Disclaimer	iv
Acknowledgements	iv
Regulatory Compliance Statements	iv
Declaration of Conformity	iv
RoHS Compliance	v
Warranty and RMA	vi
Safety Information	viii
Installation Recommendations	viii
Safety Precautions	ix
Technical Support and Assistance	x
Conventions Used in this Manual	x
Global Service Contact Information	xi
Package Contents	xiii
Ordering Information	xiii

Chapter 1: Product Introduction

Key Features	1
Hardware Specifications	2
Product Overview	4
Rear Top	4
Rear Bottom	4
Mechanical Dimensions	5

Chapter 2: Jumpers and Connectors

Before You Begin	6
Precautions	6
Jumper Settings	7
System Main Motherboard Overview	8
Location of Jumpers and Connectors on the Main Motherboard	8
External I/O	10
Internal I/O	14
DIP Switch and Jumper Settings	14
Connectors and Headers	17
Block Diagram	30

Chapter 3: System Setup

Removing the Rear Cover from the Chassis	31
Installing DDR, SSD, WiFi module	32
Installing VESA Mount Kit	34
Installing Open Frame Kit	34
System Dimensions with Open Frame Kit	35
Panel Mounting	36

Chapter 4: BIOS Setup

About BIOS Setup	31
When to Configure the BIOS.....	31
Default Configuration.....	32
Entering Setup	32
Legends	32
BIOS Setup Utility.....	34
Main.....	34
Advanced	35
Security.....	43
Boot	44
Save & Exit.....	45



PREFACE

Copyright

This publication, including all photographs, illustrations and software, is protected under international copyright laws, with all rights reserved. No part of this manual may be reproduced, copied, translated or transmitted in any form or by any means without the prior written consent from NEXCOM International Co., Ltd.

Disclaimer

The information in this document is subject to change without prior notice and does not represent commitment from NEXCOM International Co., Ltd. However, users may update their knowledge of any product in use by constantly checking its manual posted on our website: <http://www.nexcom.com>. NEXCOM shall not be liable for direct, indirect, special, incidental, or consequential damages arising out of the use of any product, nor for any infringements upon the rights of third parties, which may result from such use. Any implied warranties of merchantability or fitness for any particular purpose is also disclaimed.

Acknowledgements

XPPC 24-10N97 is the trademarks of NEXCOM International Co., Ltd. All other product names mentioned herein are registered trademarks of their respective owners.

Regulatory Compliance Statements

This section provides the FCC compliance statement for Class A devices and describes how to keep the system CE compliant.

Declaration of Conformity

FCC

This equipment has been tested and verified to comply with the limits for a Class A digital device, pursuant to Part 15 of FCC Rules. These limits are designed to provide reasonable protection against harmful interference when the equipment is operated in a commercial environment. This equipment generates, uses, and can radiate radio frequency energy and, if not installed and used in accordance with the instructions, may cause harmful interference to radio communications. Operation of this equipment in a residential area (domestic environment) is likely to cause harmful interference, in which case the user will be required to correct the interference (take adequate measures) at their own expense.

CE

The product(s) described in this manual complies with all applicable European Union (CE) directives if it has a CE marking. For computer systems to remain CE compliant, only CE-compliant parts may be used. Maintaining CE compliance also requires proper cable and cabling techniques.

RoHS Compliance



NEXCOM RoHS Environmental Policy and Status Update

NEXCOM is a global citizen for building the digital infrastructure. We are committed to providing green products and services, which are compliant with European Union RoHS (Restriction on Use of Hazardous Substance in Electronic Equipment) directive 2011/65/EU, to be your trusted green partner and to protect our environment.

RoHS restricts the use of Lead (Pb) < 0.1% or 1,000ppm, Mercury (Hg) < 0.1% or 1,000ppm, Cadmium (Cd) < 0.01% or 100ppm, Hexavalent Chromium (Cr6+) < 0.1% or 1,000ppm, Polybrominated biphenyls (PBB) < 0.1% or 1,000ppm, and Polybrominated diphenyl Ethers (PBDE) < 0.1% or 1,000ppm.

In order to meet the RoHS compliant directives, NEXCOM has established an engineering and manufacturing task force to implement the introduction of green products. The task force will ensure that we follow the standard NEXCOM development procedure and that all the new RoHS components and new manufacturing processes maintain the highest industry quality levels for which NEXCOM are renowned.

The model selection criteria will be based on market demand. Vendors and suppliers will ensure that all designed components will be RoHS compliant.

How to recognize NEXCOM RoHS Products?

For existing products where there are non-RoHS and RoHS versions, the suffix "(LF)" will be added to the compliant product name.

All new product models launched after January 2013 will be RoHS compliant. They will use the usual NEXCOM naming convention.

Warranty and RMA

NEXCOM Warranty Period

NEXCOM manufactures products that are new or equivalent to new in accordance with industry standard. NEXCOM warrants that products will be free from defect in material and workmanship for 2 years, beginning on the date of invoice by NEXCOM.

NEXCOM Return Merchandise Authorization (RMA)

- Customers shall enclose the “NEXCOM RMA Service Form” with the returned packages.
- Customers must collect all the information about the problems encountered and note anything abnormal or, print out any on-screen messages, and describe the problems on the “NEXCOM RMA Service Form” for the RMA number apply process.
- Customers can send back the faulty products with or without accessories (manuals, cable, etc.) and any components from the card, such as CPU and RAM. If the components were suspected as part of the problems, please note clearly which components are included. Otherwise, NEXCOM is not responsible for the devices/parts.
- Customers are responsible for the safe packaging of defective products, making sure it is durable enough to be resistant against further damage and deterioration during transportation. In case of damages occurred during transportation, the repair is treated as “Out of Warranty.”
- Any products returned by NEXCOM to other locations besides the customers’ site will bear an extra charge and will be billed to the customer.

Repair Service Charges for Out-of-Warranty Products

NEXCOM will charge for out-of-warranty products in two categories, one is basic diagnostic fee and another is component (product) fee.

System Level

- Component fee: NEXCOM will only charge for main components such as SMD chip, BGA chip, etc. Passive components will be repaired for free, ex: resistor, capacitor.
- Items will be replaced with NEXCOM products if the original one cannot be repaired. Ex: motherboard, power supply, etc.
- Replace with 3rd party products if needed.
- If RMA goods can not be repaired, NEXCOM will return it to the customer without any charge.

Board Level

- Component fee: NEXCOM will only charge for main components, such as SMD chip, BGA chip, etc. Passive components will be repaired for free, ex: resistors, capacitors.
- If RMA goods can not be repaired, NEXCOM will return it to the customer without any charge.

Warnings

Read and adhere to all warnings, cautions, and notices in this guide and the documentation supplied with the chassis, power supply, and accessory modules. If the instructions for the chassis and power supply are inconsistent with these instructions or the instructions for accessory modules, contact the supplier to find out how you can ensure that your computer meets safety and regulatory requirements.

Cautions

Electrostatic discharge (ESD) can damage system components. Do the described procedures only at an ESD workstation. If no such station is available, you can provide some ESD protection by wearing an antistatic wrist strap and attaching it to a metal part of the computer chassis.

Safety Information

Before installing and using the device, note the following precautions:

- Read all instructions carefully.
- Do not place the unit on an unstable surface, cart, or stand.
- Follow all warnings and cautions in this manual.
- When replacing parts, ensure that your service technician uses parts specified by the manufacturer.
- Avoid using the system near water, in direct sunlight, or near a heating device.
- The load of the system unit does not solely rely for support from the rackmounts located on the sides. Firm support from the bottom is highly necessary in order to provide balance stability.
- The computer is provided with a battery-powered real-time clock circuit. There is a danger of explosion if battery is incorrectly replaced. Replace only with the same or equivalent type recommended by the manufacturer. Discard used batteries according to the manufacturer's instructions.

Installation Recommendations

Ensure you have a stable, clean working environment. Dust and dirt can get into components and cause a malfunction. Use containers to keep small components separated.

Adequate lighting and proper tools can prevent you from accidentally damaging the internal components. Most of the procedures that follow require only a few simple tools, including the following:

- A Philips screwdriver
- A flat-tipped screwdriver
- A grounding strap
- An anti-static pad

Using your fingers can disconnect most of the connections. It is recommended that you do not use needle-nose pliers to disconnect connections as these can damage the soft metal or plastic parts of the connectors.

Safety Precautions

1. Read these safety instructions carefully.
 2. Keep this User Manual for later reference.
 3. Disconnect this equipment from any AC outlet before cleaning. Use a damp cloth. Do not use liquid or spray detergents for cleaning.
 4. For plug-in equipment, the power outlet socket must be located near the equipment and must be easily accessible.
 5. Keep this equipment away from humidity.
 6. Put this equipment on a stable surface during installation. Dropping it or letting it fall may cause damage.
 7. The openings on the enclosure are for air convection to protect the equipment from overheating. **DO NOT COVER THE OPENINGS.**
 8. Make sure the voltage of the power source is correct before connecting the equipment to the power outlet.
 9. Place the power cord in a way so that people will not step on it. Do not place anything on top of the power cord. Use a power cord that has been approved for use with the product and that it matches the voltage and current marked on the product's electrical range label. The voltage and current rating of the cord must be greater than the voltage and current rating marked on the product.
 10. All cautions and warnings on the equipment should be noted.
 11. If the equipment is not used for a long time, disconnect it from the power source to avoid damage by transient overvoltage.
 12. Never pour any liquid into an opening. This may cause fire or electrical shock.
 13. Never open the equipment. For safety reasons, the equipment should be opened only by qualified service personnel.
 14. If one of the following situations arises, get the equipment checked by service personnel:
 - a. The power cord or plug is damaged.
 - b. Liquid has penetrated into the equipment.
 - c. The equipment has been exposed to moisture.
 - d. The equipment does not work well, or you cannot get it to work according to the user's manual.
 - e. The equipment has been dropped and damaged.
 - f. The equipment has obvious signs of breakage.
 15. Do not place heavy objects on the equipment.
 16. The unit uses a three-wire ground cable which is equipped with a third pin to ground the unit and prevent electric shock. Do not defeat the purpose of this pin. If your outlet does not support this kind of plug, contact your electrician to replace your obsolete outlet.
 17. **ATTENTION:** Risque d'explosion si la batterie est remplacée par un type incorrect. Mettre au rebus les batteries usagées selon les instructions.
- CAUTION:** Risk of explosion if battery is replaced by an incorrect type. Dispose of used batteries according to the instructions.

Technical Support and Assistance

1. For the most updated information of NEXCOM products, visit NEXCOM's website at www.nexcom.com.
2. For technical issues that require contacting our technical support team or sales representative, please have the following information ready before calling:
 - Product name and serial number
 - Detailed information of the peripheral devices
 - Detailed information of the installed software (operating system, version, application software, etc.)
 - A complete description of the problem
 - The exact wordings of the error messages

Warning!

1. Handling the unit: carry the unit with both hands and handle it with care.
2. Maintenance: to keep the unit clean, use only approved cleaning products or clean with a dry cloth.

Conventions Used in this Manual



Warning:

Information about certain situations, which if not observed, can cause personal injury. This will prevent injury to yourself when performing a task.



Caution:

Information to avoid damaging components or losing data.



Note:

Provides additional information to complete a task easily.

Global Service Contact Information

Headquarters

NEXCOM International Co., Ltd.

9F, No. 920, Zhongzheng Rd.,
Zhonghe District, New Taipei City, 235015,
Taiwan, R.O.C.
Tel: +886-2-8226-7786
Fax: +886-2-8226-7782
www.nexcom.com

Taiwan

NexAIoT Headquarters

Industry 4.0 and Cloud Services

13F, No.922, Zhongzheng Rd.,
Zhonghe District, New Taipei City,
235015, Taiwan, R.O.C.
Tel: +886-2-8226-7796
Fax: +886-2-8226-7926
Email: contact@nexcom.com.tw
www.nexaiot.com

NexAIoT Co., Ltd. Taichung Office

16F, No.250, Sec.2, Chongde Rd.,
Beitun District,
Taichung City, 406503, Taiwan, R.O.C.
Tel: +886-4-2249-1179
Fax: +886-4-2249-1172
Email: contact@nexcom.com.tw
www.nexaiot.com

NexCOBOT Taiwan Co., Ltd.

13F, No.916, Zhongzheng Rd.,
Zhonghe District,
New Taipei City, 235015, Taiwan, R.O.C.
Tel: +886-2-8226-7786
Fax: +886-2-8226-7926
Email: contact@nexcom.com.tw
www.nexcobot.com

GreenBase Technology Corp.

13F, No.922, Zhongzheng Rd.,
Zhonghe District,
New Taipei City, 235015, Taiwan, R.O.C.
Tel: +886-2-8226-7786
Fax: +886-2-8226-7900
Email: info@greenbase.com.tw
www.greenbase.com.tw

DivioTec Inc.

29F-1A, No.97, Sec.4, ChongXin Rd.,
SanChong District,
New Taipei City, 241513, Taiwan, R.O.C.
Tel: +886-2-8976-3077
Email: sales@diviotec.com
www.diviotec.com

AIoT Cloud Corp.

13F, No.922, Zhongzheng Rd.,
Zhonghe District,
New Taipei City, 23586, Taiwan, R.O.C.
Tel: +886-2-8226-7786
Fax: +886-2-8226-7782
Email: info@aiotcloud.dev
www.aiotcloud.dev

EMBUX TECHNOLOGY CO., LTD.

13F, No.916, Zhongzheng Rd.,
Zhonghe District,
New Taipei City, 235015, Taiwan, R.O.C.
Tel: +886-2-8226-7786
Fax: +886-2-8226-7782
Email: info@embux.com
www.embux.com

TMR TECHNOLOGIES CO., LTD.

13F, No.916, Zhongzheng Rd.,
Zhonghe District,
New Taipei City, 23586, Taiwan, R.O.C.
Tel: +886-2-8226-7786
Fax: +886-2-8226-7782
Email: services@tmrtek.com
www.nexcom.com

China

NEXCOM Surveillance Technology Corp.

Floor 8, Building B3, Xiufeng Industrial Zone, Gan-Keng Community, Buji Street, LongGang District, ShenZhen, 518112, China
Tel: +86-755-8364-7768
Fax: +86-755-8364-7738
Email: info@greenbase.com.tw
www.greenbase.com.tw

NEXCOM Shanghai

Room 406-407, Building C, No 154, Lane 953, Jianchuan Road, Minhang District, Shanghai, 201108, China
Tel: +86-21-5278-5868
Fax: +86-21-3251-6358
Email: sales@nexcom.cn
www.nexcom.cn

NEXGOL Chongqing

1st Building No.999,
Star Boulevard, Yongchuan Dist,
Chongqing City, 402160, China
Tel: +86-23-4960-9080
Fax: +86-23-4966-5855
Email: sales@nexgol.com.cn
<https://www.nexgol.com/>

Beijing NexGemo Technology Co.,Ltd.

Room 205, No.1, Fazhan Road., Beijing International Information Industry Base, Changping District, Beijing, 102206, China
Tel: +86-10-8072-2025
Fax: +86-10-8072-2022
Email: sales@nexgemo.cn
www.nexgemo.com

Japan

NEXCOM Japan

9F, Tamachi Hara Bldg.,
4-11-5, Shiba Minato-ku,
Tokyo, 108-0014, Japan
Tel: +81-3-5419-7830
Fax: +81-3-5419-7832
Email: sales@nexcom-jp.com
www.nexcom-jp.com

USA

NEXCOM USA

41300 Boyce Rd.,
Fremont CA 94538, USA
Tel: +1-510-656-2248
Fax: +1-510-656-2158
Email: sales@nexcom.com
www.nexcomusa.com

Package Contents

Before continuing, please verify the contents of the product package. The items included are listed in the table below.

Item	Part Number	Name	Qty
1	10W30XPPC48X0	XPPC24-10N97A 23.8" TFT Panel PC, P-CAP, air bonding, Intel® Processor N97 (A100)	1
2	50311F0530X00	Heat Spreader Screws	2
3	5050900050X00	Heat Spreader	1
4	5060200269X00	M.2 Thermal Pad	1
5	5060200715X00	Heat Spreader Thermal Pad	1
6	5060200782X00	Memory Thermal Pad	1
7	7400096011X00	POWER ADAPTER FSP:FSP096-AHAN3(9NA0961468) 96W 12V/8A W/LOCK	1

Ordering Information

The following provides ordering information.

XPPC24-10N97A (PN: 10W30XPPC48X0)

23.8" 10-point PCAP touchscreen computer, FHD LED, Intel® processor N97 w/ air bonding

Panel mount kit (P/N: 88W30XPPC00X0)

Open frame kit (P/N: 88W30XPPC01X0)

CHAPTER 1: PRODUCT INTRODUCTION



Key Features

- 23.8" TFT FHD 16:9 panel
- 10-point PCAP touchscreen with slim bezel design
- IP65 protection on the front
- Support VESA/panel/open frame mounting type
- Intel® processor N97, 6M cache, up to 3.6GHz
- 1 x DDR4 SO-DIMM, up to 16GB
- 1x M.2 Key M 2242, supports PCIe x1 & SATA for storage
- 1 x Full-size Mini PCIe, supports a Wi-Fi/LTE module
- Support DC 12V power input

Hardware Specifications

Panel

- LCD size: Innolux G-series 23.8", 16:9
- Resolution: Full HD 1920x1080
- Luminance
 - LCD panel: 350cd/m2
 - XPPC PCAP touch: 85% of panel's luminance after air bonding
- Contrast ratio: 1000
- LCD color: 16.7M
- Viewing angle: 89 (U), 89 (D), 89 (L), 89 (R)
- Touchscreen
 - 10-point PCAP (projected capacitive touch)
 - Air bonding
 - Glass surface treatment: AS

Processor

- Intel® processor N97, TDP 12W

Integrated Graphics

- Intel® UHD Graphics

System Capabilities

- TPM 2.0

Memory

1 x DDR4 SO-DIMM, non-ECC, up to 16GB

Storage Device

- 1 x M.2 Key M 2242 NVMe SSD (PCIe 3.0 x1, SATA 3.0)

Expansion Slot

- 1 x Mini PCIe slot
 - Support a Wi-Fi/BT module

I/O Interface Rear

- 1 x DC 12V input
- 2 x 1GbE RJ45 port, Intel® I210AT
- 1 x HDMI® 1.4, up to 3840x2160@30Hz
- 2 x USB 3.2 Gen 1x1, Type-A
- 2 x USB 2.0, Type-A
- 1 x Line out
- 1 x Power button
- 1 x COM port, supports RS-232/422/485
- 2 x Antenna hole

I/O Interface Internal

- 1 x 4-pin header for Line out
- 1 x 10-pin header for GPIO (4 x DI, 4 x DO)
- 1 x 9-pin header for COM2, supports RS-232
- 1 x 3-pin jumper for LCD panel voltage 3.3V/5V setting
- 1 x DC Power thru one 2-pin 3.96mm pitch ATX connector (lockable)

Mechanical

- Dimensions: 557mm (W) x 336.7mm (H) x 55mm (D)
- Weight: 6kg
- Mounting type:
 - VESA mount 100mm x 100mm
 - Panel mount
 - Open frame

Package Information

- Dimensions: 650mm x 480mm x 170mm
- Weight: 8.5kg

Environment

- Vibration
 - IEC 60068-2-64
 - 2Grms@sine, 5Hz~500Hz, 1hr/axis
 - 2.2Grms@random condition, 5Hz~500Hz, 0.5hr/axis (non-operating)
- Shock
 - IEC 60068-2-27
 - 20g peak acceleration (11 msec. duration)
- Temperature
 - 0°C~50°C with 0.7 m/s air flow
 - Storage temperature: -20°C~60°C
- Operating humidity: 10%~90% relative humidity, non-condensing limits to be at 90%

Power Supply

- DC +12V power input
- 1 x 96W AC/DC lockable power adapter included in accessory

Certification

- CE (EN 55035 + EN 55032)
- FCC Class A (EMI Part 15B)
- LVD (EN 62368-1)

Operating System Support

- Windows 11
- Windows 10, 64bit
- Linux

Product Overview

Rear Top



Rear Bottom



- 1 Antenna Holes
- 2 Line Out
- 3 RS-232/422/485 COM Port
- 4 USB 2.0 Type-A Ports
- 5 USB 3.2 Gen 1x1 Type-A Ports
- 6 1GbE LAN Ports
- 7 HDMI® 1.4
- 8 12V DC Input
- 9 Power Button
- 10 Ground

CHAPTER 2: JUMPERS AND CONNECTORS

This chapter describes how to set the jumpers and connectors on the XPPC 24-10N97A motherboard.

Before You Begin

- Ensure you have a stable, clean working environment. Dust and dirt can get into components and cause a malfunction. Use containers to keep small components separated.
- Adequate lighting and proper tools can prevent you from accidentally damaging the internal components. Most of the procedures that follow require only a few simple tools, including the following:
 - A Philips screwdriver
 - A flat-tipped screwdriver
 - A set of jewelers screwdrivers
 - A grounding strap
 - An anti-static pad
- Using your fingers can disconnect most of the connections. It is recommended that you do not use needle-nosed pliers to disconnect connections as these can damage the soft metal or plastic parts of the connectors.
- Before working on internal components, make sure that the power is off. Ground yourself before touching any internal components, by touching a metal object. Static electricity can damage many of the electronic components. Humid environments tend to have less static electricity

than dry environments. A grounding strap is warranted whenever danger of static electricity exists.

Precautions

Computer components and electronic circuit boards can be damaged by discharges of static electricity. Working on computers that are still connected to a power supply can be extremely dangerous.

Follow the guidelines below to avoid damage to your computer or yourself:

- Always disconnect the unit from the power outlet whenever you are working inside the case.
- If possible, wear a grounded wrist strap when you are working inside the computer case. Alternatively, discharge any static electricity by touching the bare metal chassis of the unit case, or the bare metal body of any other grounded appliance.
- Hold electronic circuit boards by the edges only. Do not touch the components on the board unless it is necessary to do so. Don't flex or stress the circuit board.
- Leave all components inside the static-proof packaging that they shipped with until they are ready for installation.
- Use correct screws and do not over tighten screws.

Jumper Settings

A jumper is the simplest kind of electric switch. It consists of two metal pins and a cap. When setting the jumpers, ensure that the jumper caps are placed on the correct pins. When the jumper cap is placed on both pins, the jumper is short. If you remove the jumper cap, or place the jumper cap on just one pin, the jumper is open.

Refer to the illustrations below for examples of what the 2-pin and 3-pin jumpers look like when they are short (on) and open (off).

Two-Pin Jumpers: Open (Left) and Short (Right)

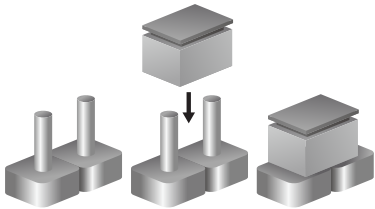

Three-Pin Jumpers: Pins 1 and 2 are Short

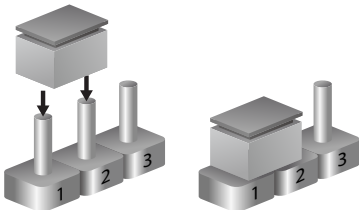

System Main Motherboard Overview

This section outlines the location and pin assignments of jumpers and connectors, with reference illustrations (not to scale) and pink-marked pin definitions to aid understanding.

Location of Jumpers and Connectors on the Main Motherboard

Top View

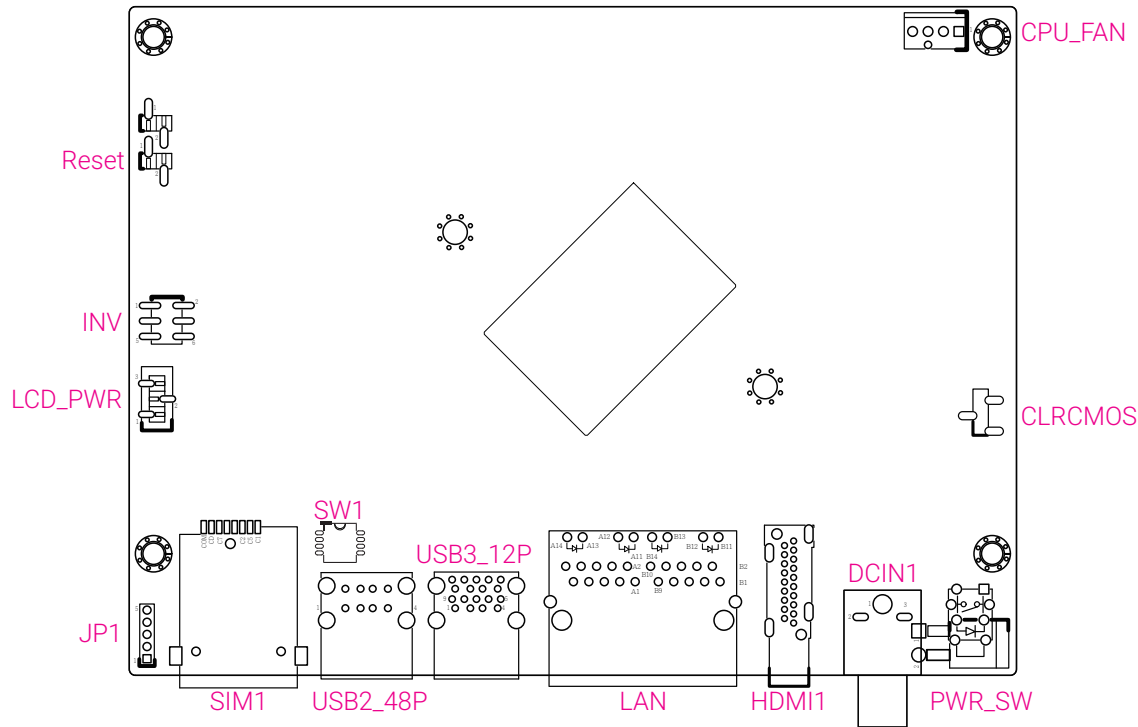

Bottom View

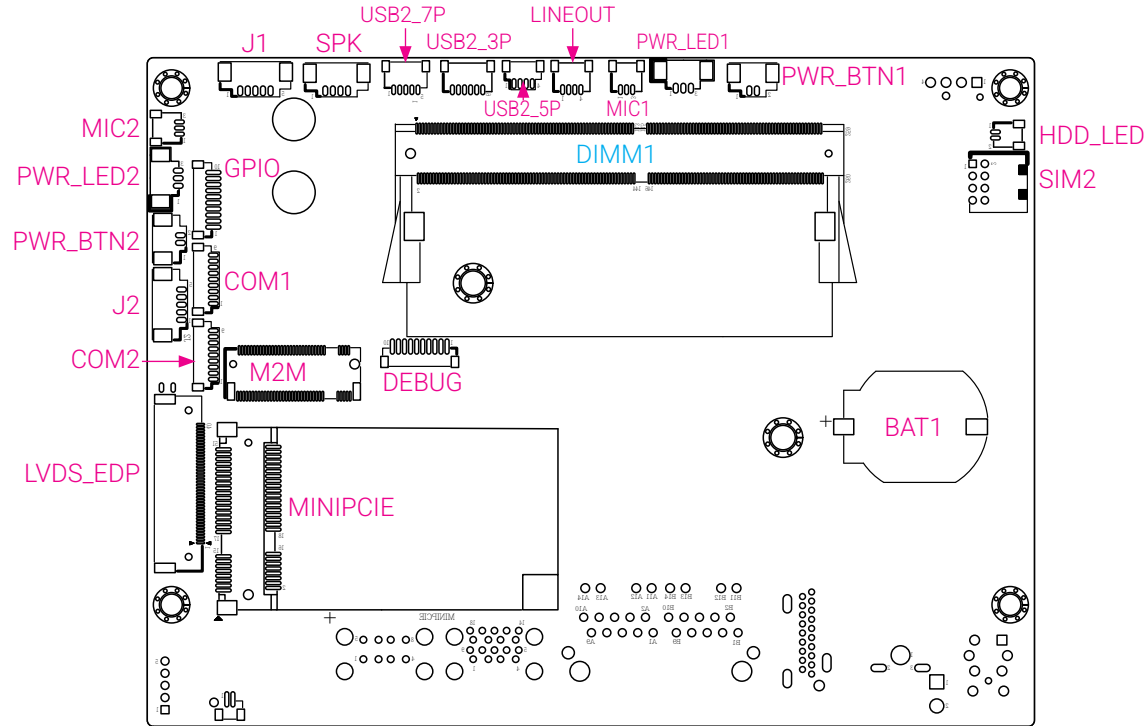

External I/O

COM1

Connector connector: DB9
 Connector interface: RS-232/422/485
 Connector location: COM1

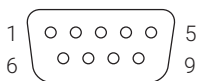

Pin	Definition	Pin	Definition
1	DCD	2	RXD
3	TXD	4	DTR
5	GND	6	DSR
7	RTS	8	CTS
9	RI		



Refer to the [BIOS chapter](#) for instructions on configuring the serial port mode.

COM2

Connector connector: DB9
 Connector interface: RS-232
 Connector location: COM2

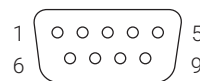

Pin	Definition	Pin	Definition
1	DCD	2	RXD
3	TXD	4	DTR
5	GND	6	DSR
7	RTS	8	CTS
9	RI		

DC Input

Connector location: DCIN1

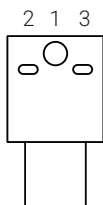

Pin	Definition
1	DCIN
2	GND
3	GND

HDMI®

Connector location: HDMI1

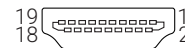

Pin	Definition	Pin	Definition
1	HDMI_TX2P	2	GND
3	HDMI_TX2N	4	HDMI_TX1P
5	GND	6	HDMI_TX1N
7	HDMI_TX0P	8	GND
9	HDMI_TX0N	10	HDMI_CLK_P
11	GND	12	HDMI_CLK_N
13	NC	14	NC
15	HDMI_SCL	16	HDMI_SDA
17	GND	18	HDMI_P5V
19	HDMI_HPD		

LAN Ports

Connector type: RJ45

Connector location: LAN

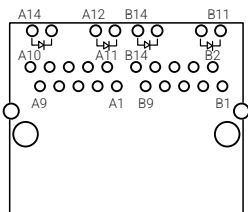

Pin	Definition	Pin	Definition
A1	LAN1_MDI0P	B1	LAN2_MDI0P
A3	LAN1_MDI1P	B3	LAN2_MDI1P
A5	LAN1_MDI2N	B5	LAN2_MDI2N
A7	LAN1_MDI3P	B7	LAN2_MDI3P
A9	LAN1_TCT	B9	LAN2_TCT
A11	LAN1_LED_1000#	B11	LAN2_LED_1000#
A13	LAN1_LED_ACT#	B13	LAN2_LED_ACT#
A2	LAN1_MDI0N	B2	LAN2_MDI0N
A4	LAN1_MDI2P	B4	LAN2_MDI2P
A6	LAN1_MDI1N	B6	LAN2_MDI1N
A8	LAN1_MDI3N	B8	LAN2_MDI3N
A10	GND	B10	GND
A12	LAN1_LED_100#	B12	LAN2_LED_100#
A14	LAN1_LED_ACTP	B14	LAN2_LED_ACTP

Act (Left)	Status	Link (Right)	Status
Blinking yellow	Activity	Solid green	2.5/1Gbp/s network link
Off	Inactivity	Solid yellow	100Mbp/s network link
		Off	10Mbps, no link

USB 3.2 Ports

Connector type: USB Type-A

Connector location: USB3_12P

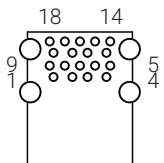

Pin	Definition	Pin	Definition
1	+5V	2	USB2_1N
3	USB2_1P	4	GND
5	USB3_RX1N	6	USB3_RX1P
7	GND	8	USB3_TX1N
9	USB3_TX1P	10	+5V
11	USB2_2N	12	USB2_2P
13	GND	14	USB3_RX2N
15	USB3_RX2P	16	GND
17	USB3_TX2N	18	USB3_TX2P

USB 2.0 Ports

Connector type: USB Type-A

Connector location: USB2_48P

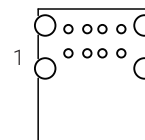

Pin	Definition	Pin	Definition
1	+5V	2	USB2_1N
3	USB2_1P	4	GND
5	+5V	6	USB2_2N
7	USB2_2P	8	GND

Internal I/O

DIP Switch and Jumper Settings Clear CMOS

Connector location: CLRCMOS



Pin	Settings
1-2	Normal (default)
2-3	Clear CMOS

COM2 RI Select

Connector location: JP1

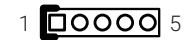

Pin	Settings
1-2	COM2 RI = Ring (default)
2-3	COM2 RI = +5V
4-5	COM2 RI = +12V

LCD Panel Voltage Select

Connector location: LCD_PWR



Pin	Settings
1-2	+3.3V (default)
2-3	+5V

LVDS Resolution Select

Connector location: SW1

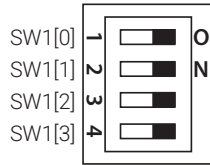

GPIO[3:0]	SW1[3]	SW1[2]	SW1[1]	SW1[0]	HA	VA	CD(bit)	port
0000	ON	ON	ON	ON	800	600	6	single
0001	ON	ON	ON	OFF	1024	768	6	single
0010	ON	ON	OFF	ON	1024	768	8	single
0011	ON	ON	OFF	OFF	1280	1024	6	single
0100	ON	OFF	ON	ON	1280	800	6	single
0101	ON	OFF	ON	OFF	1280	960	6	single
0110	ON	OFF	OFF	ON	1280	1024	8	dual
0111	ON	OFF	OFF	OFF	1366	768	6	single
1000	OFF	ON	ON	ON	1366	768	8	single
1001	OFF	ON	ON	OFF	1440	900	8	dual
1010	OFF	ON	OFF	ON	1400	1050	8	dual
1011	OFF	ON	OFF	OFF	1600	900	8	dual
1100	OFF	OFF	ON	ON	1680	1050	8	dual
1101	OFF	OFF	ON	OFF	1600	1200	8	dual
1110	OFF	OFF	OFF	ON	1920	1080	8	dual
1111	OFF	OFF	OFF	OFF	1920	1200	8	dual

Connectors and Headers

Battery Connector

Connector location: BAT1

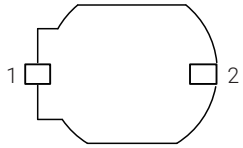

Pin	Definition
1	GND
2	BAT

COM Port

Connector location: COM1, COM2

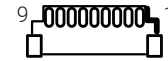

Pin	RS-232	Pin	RS-422	Pin	RS-485
1	RI#	1	NC	1	NC
2	CTS#	2	NC	2	NC
3	RTS#	3	NC	3	NC
4	DSR#	4	NC	4	NC
5	GND	5	NC	5	NC
6	DTR#	6	RX-	6	NC
7	TXD	7	RX+	7	NC
8	RXD	8	TX+	8	D+
9	DCD	9	TX-	9	D-

Fan Connector

Connector location: CPU_FAN

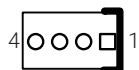

Pin	Definition
1	GND
2	+12V
3	CPU FAN SPEED DETECT
4	CPU FAN SPEED CONTROL

80 Debug Port

Connector location: Debug



Pin	Definition	Pin	Definition
1	GND	2	PLTRST#
3	ESPI_CLK	4	ESPI_CS#
5	ESPI_IO3	6	ESPI_IO2
7	ESPI_IO1	8	ESPI_IO0
9	ESPI_RST#	10	3.3V

GPIO

Connector location: GPIO

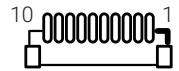

Pin	Definition	Pin	Definition
1	+5V	2	GND
3	GPO0	4	GPO1
5	GPO2	6	GPO3
7	GPI0	8	GPI1
9	GPI2	10	GPI3

Storage LED

Connector location: HDD_LED



Pin	Definition
1	HDD_LED_P
2	HDD_LED_N

LCD Panel Backlight Converter

Connector location: INV

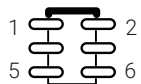

Pin	Definition	Pin	Definition
1	GND	2	GND
3	+V_INV	4	+V_INV
5	INV_BKLTEN	6	INV_BKLTCTRL

Light Sensor

Connector location: J1, J2

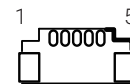

Pin	Definition
1	3.3V
2	3.3V
3	COM2_TXD
4	COM2_RXD
5	GND

LVDS or eDP Panel Connector

Connector location: LVDS_EDP1

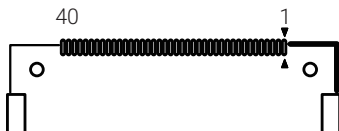

LVDS

Pin	Definition	Pin	Definition
1	LVDS_DAT3P	21	GND
2	LVDS_DAT3N	22	+V_PANEL
3	LVDS_DAT2P	23	GND
4	LVDS_DAT2N	24	GND
5	LVDS_DAT1P	25	GND
6	LVDS_DAT1N	26	LVDS_CLK1P
7	LVDS_DAT0P	27	LVDS_CLK1N
8	LVDS_DAT0N	28	GND
9	LVDS_DAT7P	29	GND
10	LVDS_DAT7N	30	GND
11	LVDS_DAT6P	31	Hot-Plug Detect
12	LVDS_DAT6N	32	INV_BKLTEN
13	LVDS_DAT5P	33	INV_BKLTCTRL
14	LVDS_DAT5N	34	LVDS_CLK2P
15	LVDS_DAT4P	35	LVDS_CLK2N
16	LVDS_DAT4N	36	+V_INV
17	GND	37	+V_INV
18	+V_PANEL	38	+V_INV
19	+V_PANEL	39	+V_INV
20	+V_PANEL	40	N.C.

eDP

Pin	Definition	Pin	Definition
1	N.C.	21	GND
2	N.C.	22	+V_PANEL
3	EDP_TX0P	23	GND
4	EDP_TX0N	24	GND
5	EDP_TX1P	25	GND
6	EDP_TX1N	26	EDP_AUXP
7	EDP_HPDP	27	EDP_AUXN
8	N.C.	28	GND
9	N.C.	29	GND
10	N.C.	30	GND
11	N.C.	31	Hot-Plug Detect
12	N.C.	32	INV_BKLTEN
13	N.C.	33	INV_BKLTCTRL
14	N.C.	34	N.C.
15	N.C.	35	N.C.
16	N.C.	36	+V_INV
17	GND	37	+V_INV
18	+V_PANEL	38	+V_INV
19	+V_PANEL	39	+V_INV
20	+V_PANEL	40	GND

M.2 Key M

Connector location: M2M



Pin	Definition	Pin	Definition
1	GND	2	VCC3
3	GND	4	VCC3
5	PCIE3_RXN	6	NC
7	PCIE3_RXP	8	NC
9	GND	10	M2M_LED#
11	PCIE3_TXN	12	VCC3
13	PCIE3_TXP	14	VCC3
15	GND	16	VCC3
17	PCIE2_RXN	18	VCC3
19	PCIE2_RXP	20	NC
21	GND	22	NC
23	PCIE2_TXN	24	NC
25	PCIE2_TXP	26	NC
27	GND	28	NC
29	PCIE1_RXN	30	NC
31	PCIE1_RXP	32	NC
33	GND	34	NC
35	PCIE1_TXN	36	NC

Pin	Definition	Pin	Definition
37	PCIE1_TXP	38	DEVSLP
39	GND	40	NC
41	SATA_RXP(PCIE0_RXP)	42	NC
43	SATA_RXN(PCIE0_RXN)	44	NC
45	GND	46	NC
47	SATA_TXN(PCIE0_TXN)	48	NC
49	SATA_TXP(PCIE0_TXP)	50	RESET#
51	GND	52	CLKREQ#
53	CLK_PCIEN	54	WAKE#
55	CLK_PCIEP	56	NC
57	GND	58	NC
Key			
67	NC	68	NC
69	M2M_PEDET	70	VCC3
71	GND	72	VCC3
73	GND	74	VCC3
75	GND		

Mic In

Connector location: MIC1, MIC2

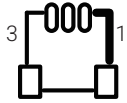

Pin	Definition
1	MIC_R
2	GND
3	MIC_L

Mini PCIe

Connector location: MINIPCIIE

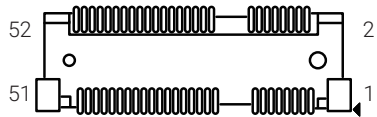

Pin	Definition	Pin	Definition
1	WAKE#	2	3.3V
3	NC	4	GND
5	NC	6	1.5V
7	CLKREQ#	8	UIM_PWR
9	GND	10	UIM_DATA
11	CLKN0	12	UIM_CLK
13	CLKP0	14	UIM_RESET
15	GND	16	UIM_VPP
17	NC	18	GND
19	NC	20	W_DIS#
21	GND	22	RESET#
23	PCIE5_RXN / SATA_RXP	24	3.3V
25	PCIE5_RXP / SATA_RXN	26	GND

Pin	Definition	Pin	Definition
27	GND	28	1.5V
29	GND	30	SMB_CLK
31	PCIE5_TXN / SATA_TXN	32	SMB_DATA
33	PCIE5_TXP / SATA_TXP	34	GND
35	GND	36	USB2_6DN
37	GND	38	USB2_6DP
39	3.3V	40	GND
41	3.3V	42	NC
43	GND	44	NC
45	NC	46	NC
47	NC	48	1.5V
49	NC	50	GND
51	mSATA Presece Detection	52	3.3V

System Power Button

Connector location: PWR_BTN1, PWR_BTN2

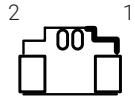

Pin	Definition
1	GND
2	PWRBTN#

Power LED

Connector location: PWR_LED1, PWR_LED2

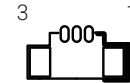

Pin	Definition
1	PWRLED_P
2	NC
3	PWRLED_N

Reset

Connector location: Reset

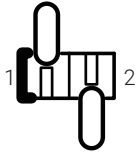

Pin	Definition
1	RESET#
2	GND

SIM

Connector location: SIM1

Connector location: SIM2

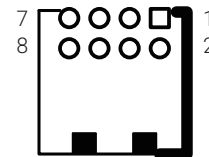
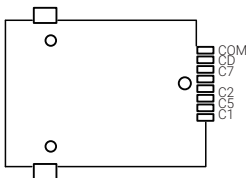

Pin	Definition	Pin	Definition
MH1	CGND	MH2	CGND
COM	GND	CD	GND
C3	SIM_CLK	C7	SIM_DATA
C2	SIM_RESET	C6	SIM_VPP
C1	SIM_PWR	C5	GND

Pin	Definition
1	SIM_DATA
2	SIM_CLK
3	SIM_VPP
4	SIM_RESET
5	GND
6	SIM_PWR
7	NC
8	NC

Sperker

Connector location: SPK

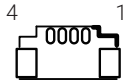

Pin	Definition
1	R_OUT-
2	R_OUT+
3	L_OUT-
4	L_OUT+

USB 2.0 x1

Connector location: USB2_3P

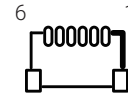

Pin	Definition
1	GND
2	USB_N
3	USB_P
4	NC
5	NC
6	5VSB



USB 2.0 x1

Connector location: USB2_5P

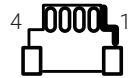

Pin	Definition
1	GND
2	USB_N
3	USB_P
4	5VSB

Connector location: USB2_7P

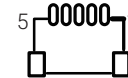

Pin	Definition
1	GND
2	USB_N
3	USB_P
4	5VSB
5	5VSB



Block Diagram

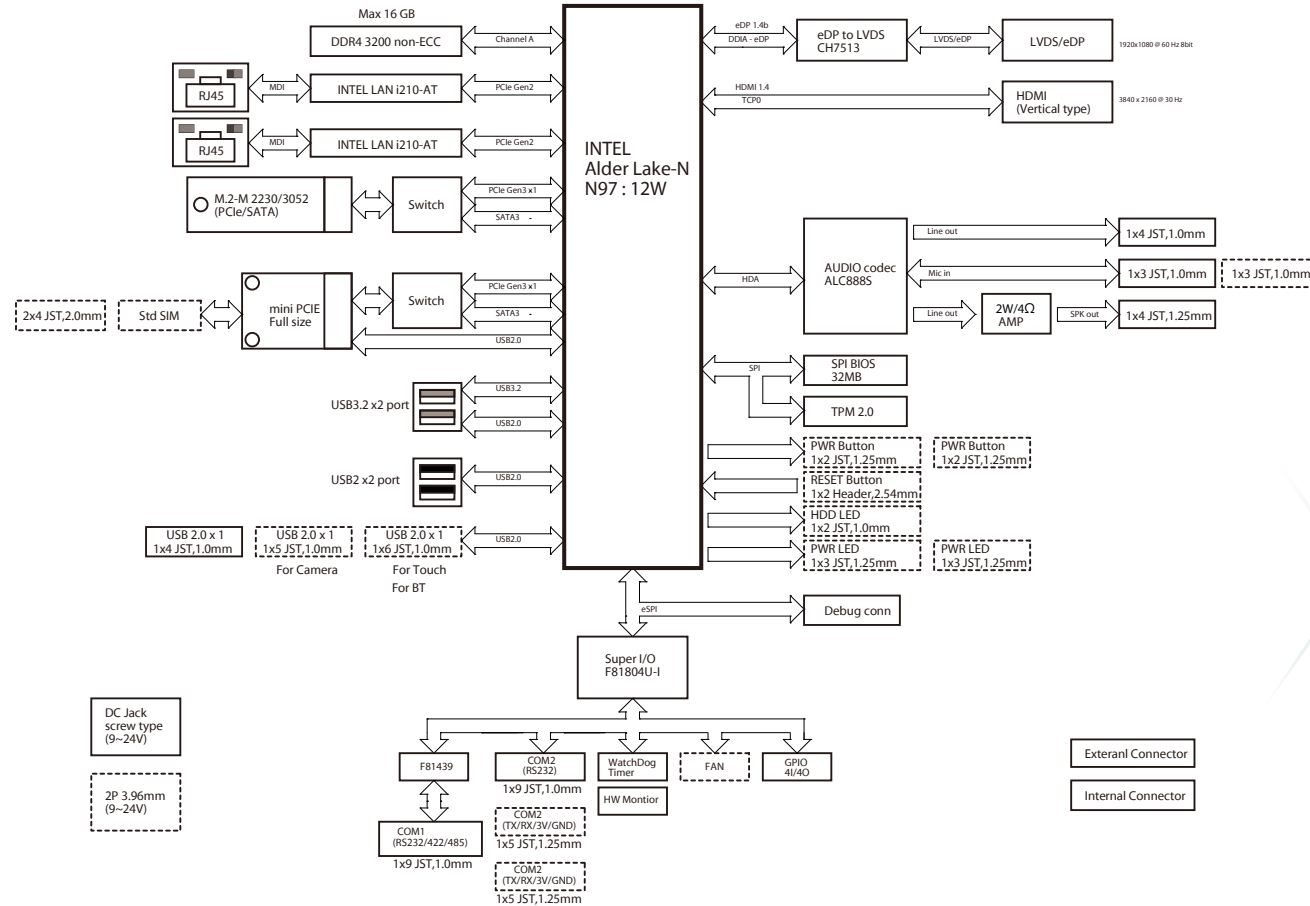

CHAPTER 3: SYSTEM SETUP

Removing the Rear Cover from the Chassis

- Remove the 7 screws from the rear cover, then lift up the system chassis box to access the mainboard.

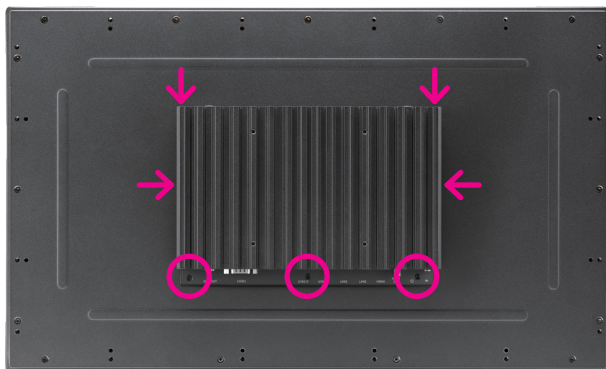

Prior to removing the top cover, make sure the unit's power is off and disconnected from the power sources to prevent electric shock or system damage.

Installing DDR, SSD, WiFi module

1. With the rear cover removed, locate the connectors indicated below to install the modules: 1. Mini PCIe for Wi-Fi or storage, 2. M.2 for Storage, 3. SO-DIMM for System memory.

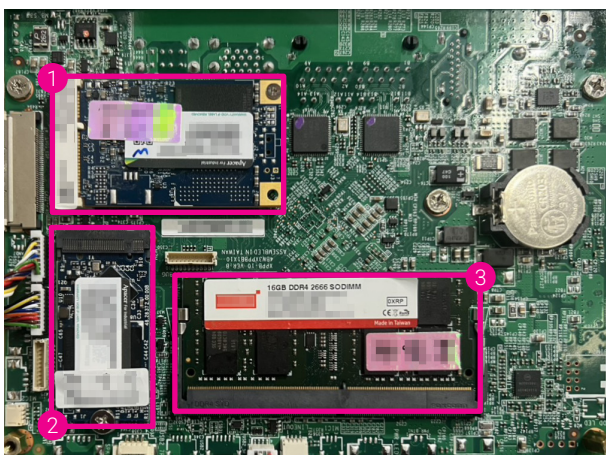

2. Once the M.2 and/or memory module(s) have been installed, peel off the film attached to the thermal pad, then apply it to the module(s).

- Installing the Memory Thermal Pad

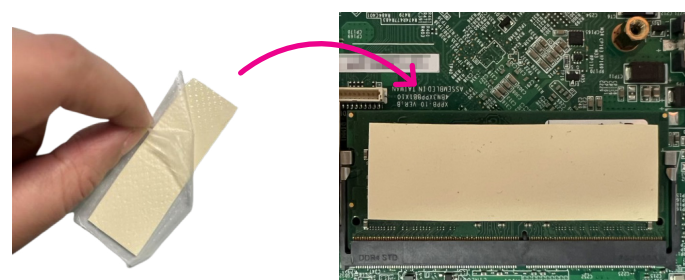

Thermal pad dimension: 60x20x2.0mm (PN: 5060200782X00)

- Installing the M.2 thermal pad

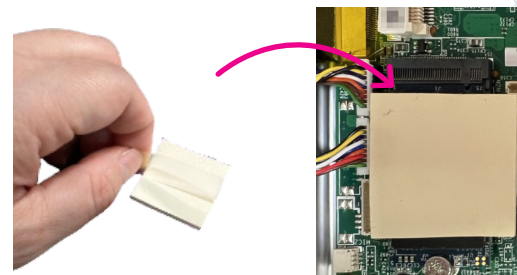

Thermal pad dimension: 10x10x5.0mm (PN: 5060200629X00)

3. Peel off the film attached to the thermal pad, then apply it to the heat spreader (PN: 5050900050X00).



Thermal pad dimension: 171x60x28.2mm (PN: 5060200715X00)

4. Refer to the location shown in the image below, then secure the heat spreader. When securing the heat spreader, be careful not to pinch the cables. Before fastening the screw, gently press down on the heat spreader.

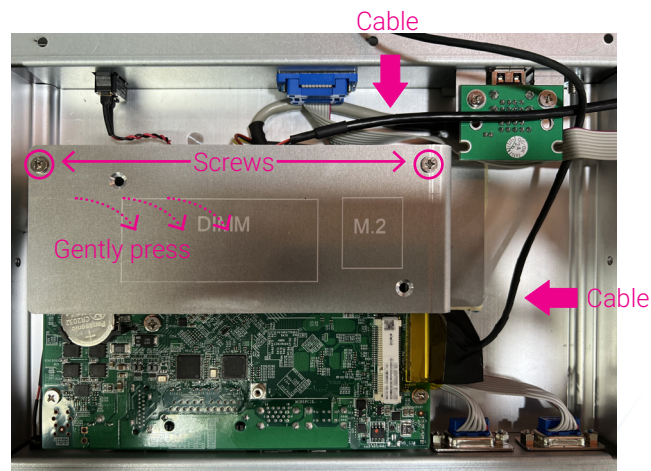

Installing VESA Mount Kit

- Align the mounting holes on the VESA mount bracket to the VESA mounting holes on the rear of the panel PC, then secure the VESA mount bracket with screws. Recommended screws for the VESA mount kit: 4 * M4x8 screws.



Installing Open Frame Kit

- Turn to the rear side of the panel PC and align the mounting holes on the open frame bracket to the open frame mounting holes on the panel PC, then secure the open frame bracket with screws.

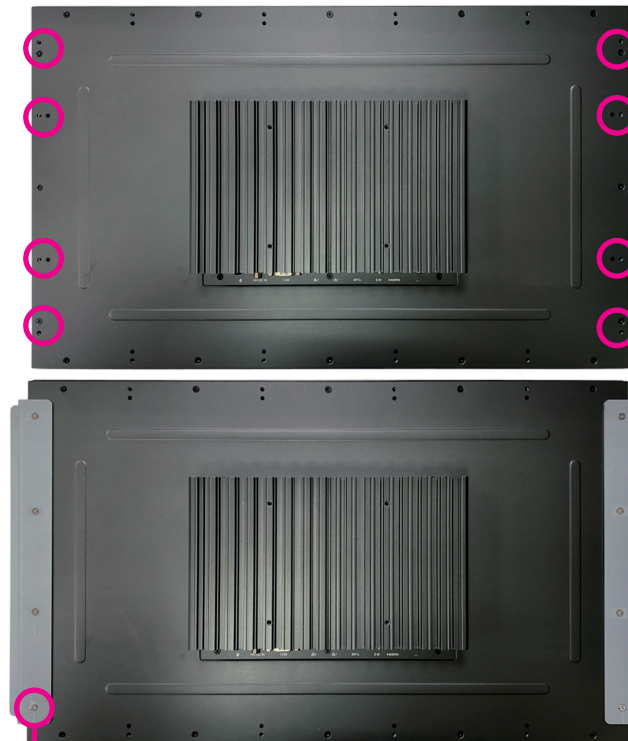

8 * Screws (F3x5 Nylok NI+Heat)

System Dimensions with Open Frame Kit

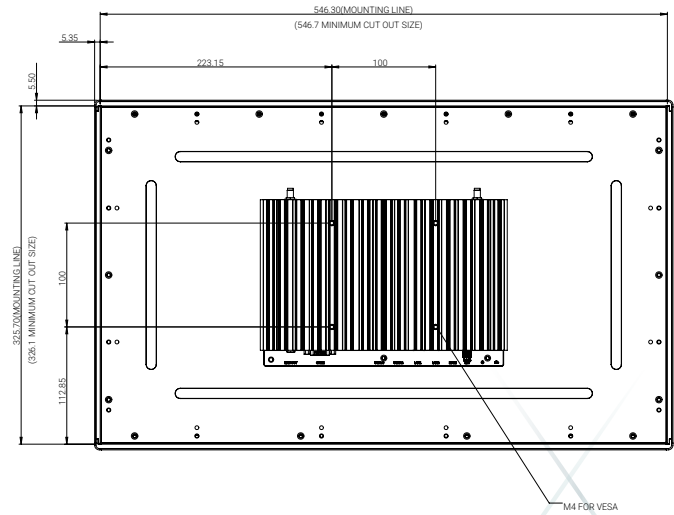
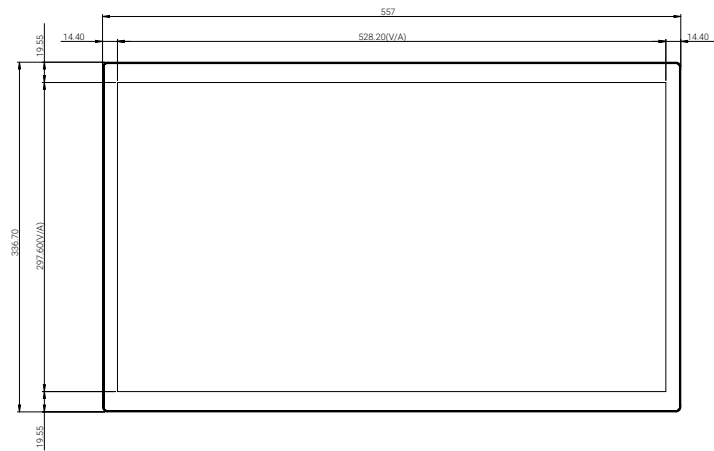

Panel Mounting

1. Select a place on the panel where you will mount the panel PC.
2. Cut out a shape on the panel that corresponds to the panel PC's rear dimensions.

The thickness of the panel (e.g. steel board, plank, acrylic board, wall, etc.) where you will mount the panel PC must not exceed 9.5mm. If the distance between the front bezel and panel mount hole is too wide, it will not fit the panel mount kit.

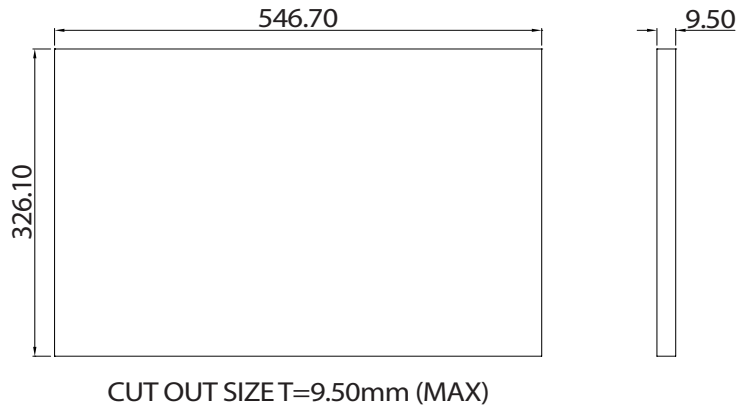

3. Slide the panel PC through the hole until it is properly fitted against the panel.

4. Position the mounting clamps along the rear edges of the panel PC. The first and second clamps must be positioned and secured diagonally prior to mounting the rest of the clamps.

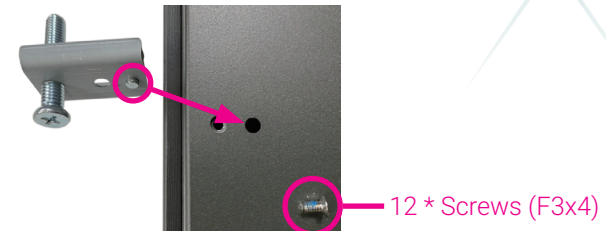
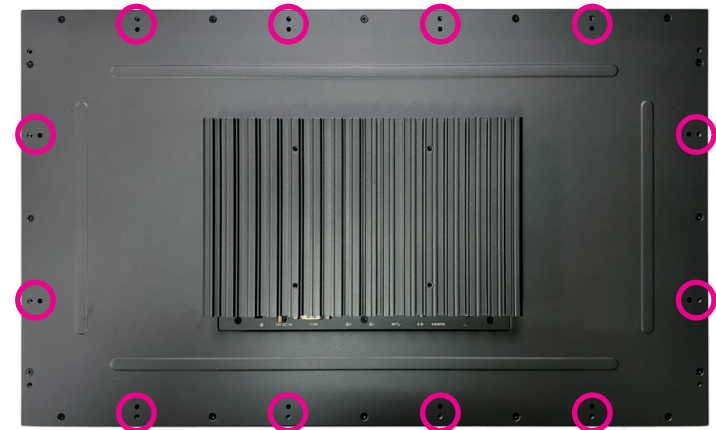

5. Tighten the clamp's screw until it touches the panel.

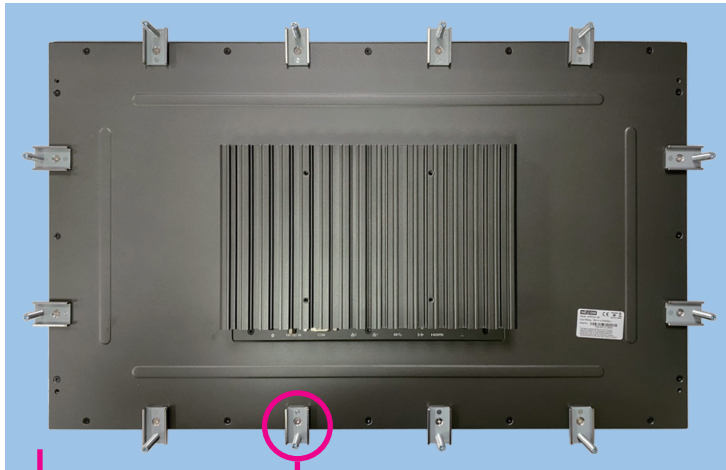

Panel

Clamp



Do not overtighten the screws to prevent damaging the Panel PC.

CHAPTER 4: BIOS SETUP

This chapter describes how to use the BIOS setup program for XPPC 24-10N97A. The BIOS screens provided in this chapter are for reference only and may change if the BIOS is updated in the future.

To check for the latest updates and revisions, visit the NEXCOM website at www.nexcom.com.tw.

About BIOS Setup

The BIOS (Basic Input and Output System) Setup program is a menu driven utility that enables you to make changes to the system configuration and tailor your system to suit your individual work needs. It is a ROM-based configuration utility that displays the system's configuration status and provides you with a tool to set system parameters.

These parameters are stored in non-volatile battery-backed-up CMOS RAM that saves this information even when the power is turned off. When the system is turned back on, the system is configured with the values found in CMOS.

With easy-to-use pull down menus, you can configure such items as:

- Hard drives, diskette drives, and peripherals
- Video display type and display options
- Password protection from unauthorized use

- Power management features

The settings made in the setup program affect how the computer performs. It is important, therefore, first to try to understand all the setup options, and second, to make settings appropriate for the way you use the computer.

When to Configure the BIOS

- This program should be executed under the following conditions:
- When changing the system configuration
- When a configuration error is detected by the system and you are prompted to make changes to the setup program
- When resetting the system clock
- When redefining the communication ports to prevent any conflicts
- When making changes to the Power Management configuration
- When changing the password or making other changes to the security setup

Normally, CMOS setup is needed when the system hardware is not consistent with the information contained in the CMOS RAM, whenever the CMOS RAM has lost power, or the system features need to be changed.

Default Configuration

Most of the configuration settings are either predefined according to the Load Optimal Defaults settings which are stored in the BIOS or are automatically detected and configured without requiring any actions. There are a few settings that you may need to change depending on your system configuration.

Entering Setup











When the system is powered on, the BIOS will enter the Power-On Self Test (POST) routines. These routines perform various diagnostic checks; if an error is encountered, the error will be reported in one of two different ways:

- If the error occurs before the display device is initialized, a series of beeps will be transmitted.
- If the error occurs after the display device is initialized, the screen will display the error message.

Powering on the computer and immediately pressing allows you to enter Setup.

Press the  key to enter Setup:

Legends

Key	Function
	Moves the highlight left or right to select a menu.
	Moves the highlight up or down between sub-menus or fields.
	Exits the BIOS Setup Utility.
	Scrolls forward through the values or options of the highlighted field.
	Scrolls backward through the values or options of the highlighted field.
	Selects a field.
	Displays General Help.
	Load previous values.
	Load optimized default values.
	Saves and exits the Setup program.
	Press <Enter> to enter the highlighted sub-menu

Scroll Bar

When a scroll bar appears to the right of the setup screen, it indicates that there are more available fields not shown on the screen. Use the up and down arrow keys to scroll through all the available fields.

Submenu

When "▶" appears on the left of a particular field, it indicates that a submenu which contains additional options are available for that field. To display the submenu, move the highlight to that field and press .

BIOS Setup Utility

Once you enter the AMI BIOS Setup Utility, the Main Menu will appear on the screen. The main menu allows you to select from several setup functions and one exit. Use arrow keys to select among the items and press  to accept or enter the submenu.

Main

The Main menu is the first screen that you will see when you enter the BIOS Setup Utility.

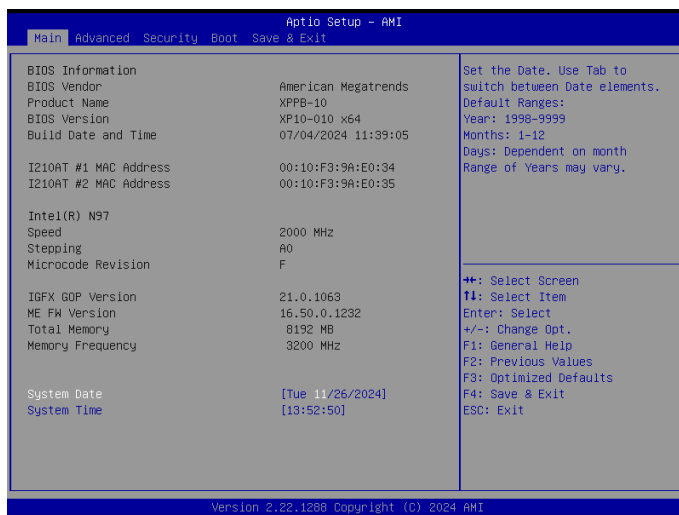

System Date

The date format is <day>, <month>, <date>, <year>. Day displays a day, from Monday to Sunday. Month displays the month, from January to December. Date displays the date, from 1 to 31. Year displays the year, from 2005 to 2099.

System Time

The time format is <hour>, <minute>, <second>. The time is based on the 24-hour military-time clock. For example, 1 p.m. is 13:00:00. Hour displays hours from 00 to 23. Minute displays minutes from 00 to 59. Second displays seconds from 00 to 59.

Advanced

The Advanced menu allows you to configure your system for basic operation. Some entries are defaults required by the system board, while others, if enabled, will improve the performance of your system or let you set some features according to your preference.



Setting incorrect field values may cause the system to malfunction.

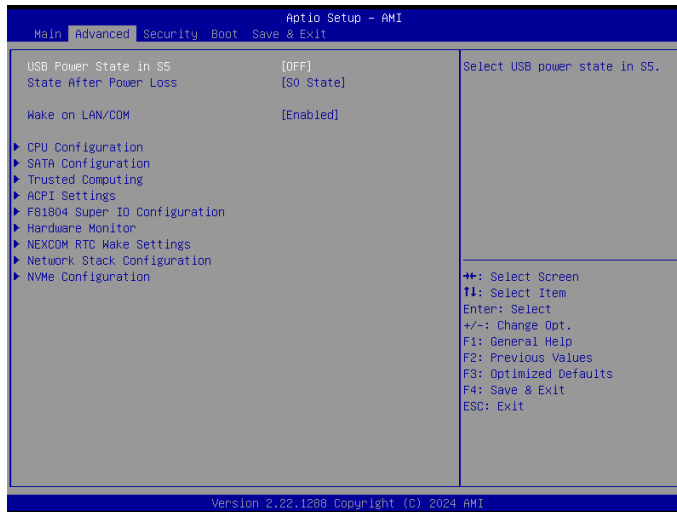

USB Power State in S5

Select USB power state in S5.

State After Power Loss

Specify what state to go to when power is re-applied after a power failure (G3 State).

Wake on LAN/COM

Enable or disable integrated LAN/COM port RI to wake the system.

CPU Configuration



Efficient-core Information

Displays the E-core information.

SATA Configuration



SATA Controller(s)

Enable or disable SATA device.

SATA Test Mode

Enable or disable test mode (loop back).

Trusted Computing



Security Device Support

Enable or disable BIOS support for security device. O.S will not show Security Device. TCG EFI protocol and INT1A interface will not be available.

SHA256 PCR Bank

Enable or disable SHA256 PCR Bank

Pending operation

Schedule an operation for the security device. Note: your computer will reboot during restart in order to change state of security device.

Platform Hierarchy

Enable or disable Platform Hierarchy.

Storage Hierarchy

Enable or disable Storage Hierarchy.

Endorsement Hierarchy

Enable or disable Endorsement Hierarchy.

ACPI Settings



Enable Hibernation

Enable or disable system ability to hibernate (OS/S4 Sleep State). This option may not be effective with some OS.

ACPI Sleep State

Select the highest ACPI sleep state the system will enter when the suspend button is pressed.

F81804 Super IO Configuration



Serial Port 1/2 Configuration

Press Enter to access the submenu.

Serial Port 1 Configuration



Serial Port

Enable or disable serial port (COM).

Onboard Serial Port 1 Mode

Select a mode for serial port 1. When select RS422/485 mode.

Serial Port 1/2 Configuration

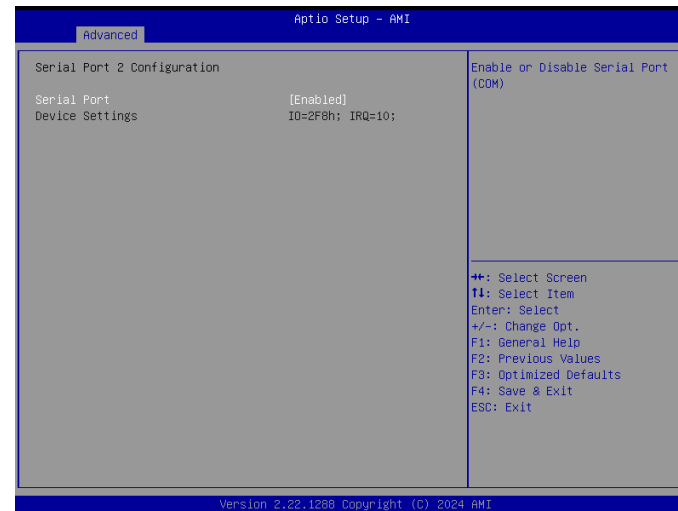

Serial Port

Enable or disable serial port (COM).

Hardware Monitor

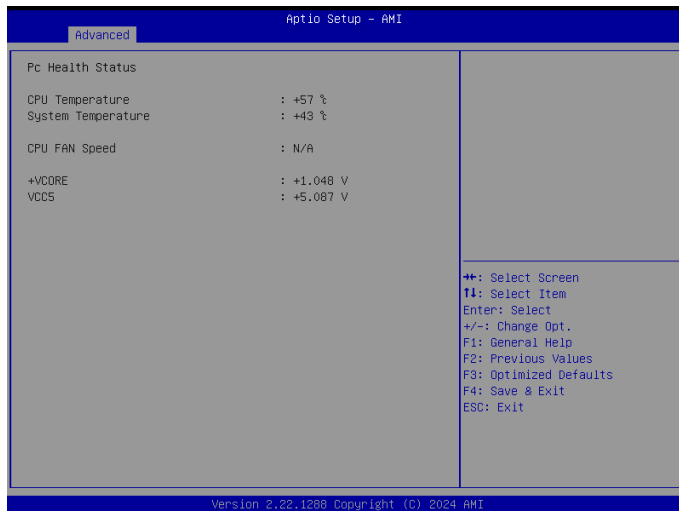

This section is used to monitor hardware status such as temperature, CPU fan speed, and voltages.

NEXCOM RTC Wake Settings

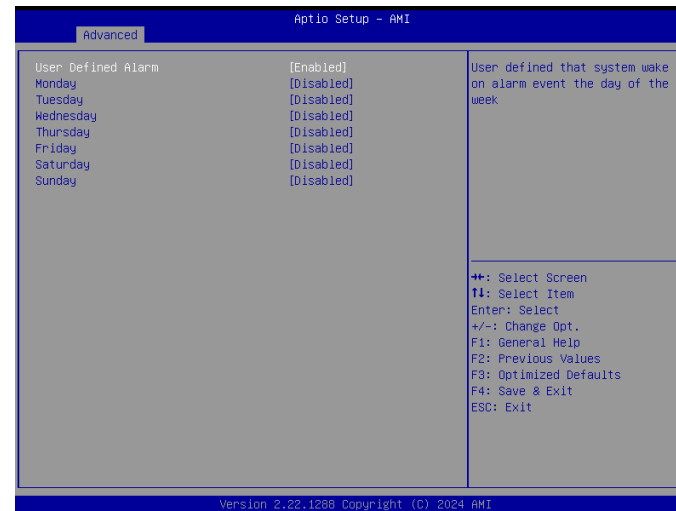

User Defined Alarm

User defined that system wake on alarm event the day of the week.

Network Stack Configuration

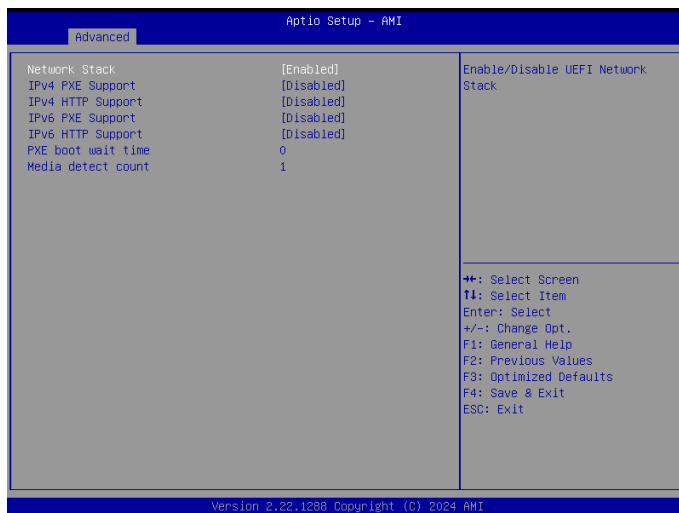

Network Stack

Enable or disable UEFI network stack. More options will be available for configuration when enabled.

Ipv4 PXE Support

Enable or disable IPv4 PXE support. If disabled, the IPv4 boot option will not be available.

Ipv4 HTTP Support

Enable or disable IPv4 HTTP support. If disabled, the IPv4 boot option will not be available.

Ipv6 PXE Support

Enable or disable IPv6 PXE support. If disabled, the IPv6 boot option will not be available.

Ipv6 HTTP Support

Enable or disable IPv6 HTTP support. If disabled, the IPv6 boot option will not be available.

PXE boot wait time

Wait time in seconds to press ESC key to abort the PXE boot. Use either +/- or numeric keys to set the value.

Media detect count

Number of times presence of media will be checked. Use either +/- or numeric keys to set the value.

NVMe Configuration

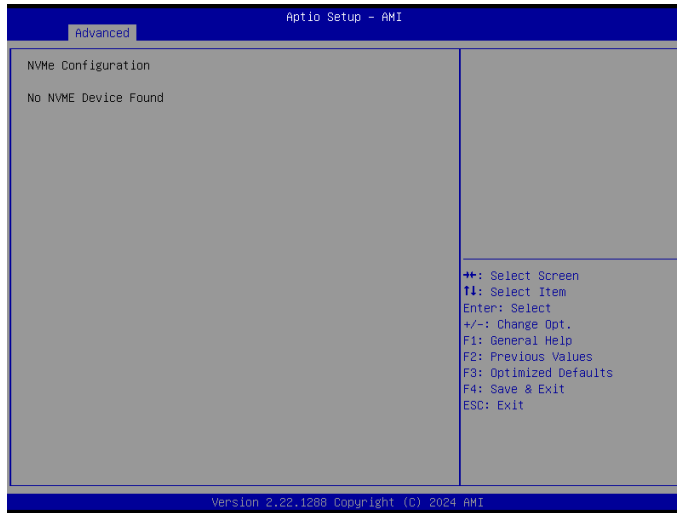

This section is used to configure the NVMe devices. The options will become available once the system detects an installed NVMe device.

Security

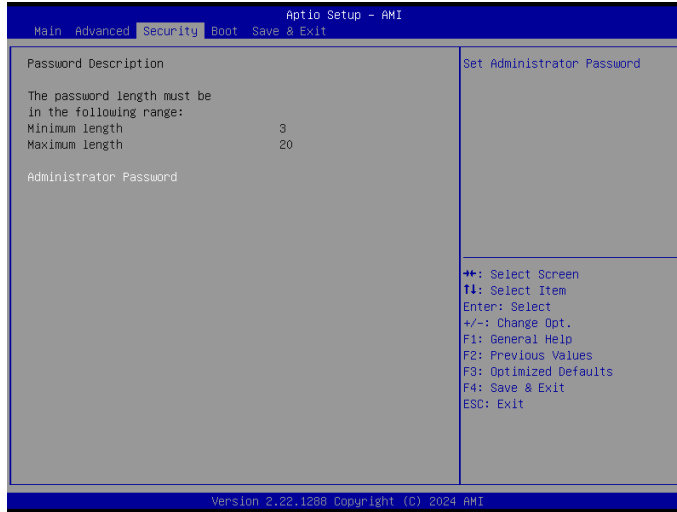

Administrator Password

Set administrator's password.

Boot

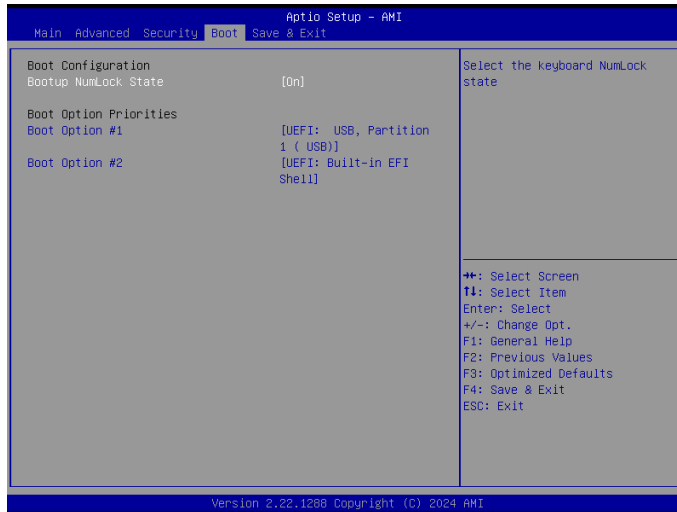

Bootup NumLock State

Select the keyboard NumLock state.

Boot Option Priorities

Adjust the boot sequence of the system. Boot Option #1 is the first boot device that the system will boot from, next will be #2 and so forth.

Save & Exit

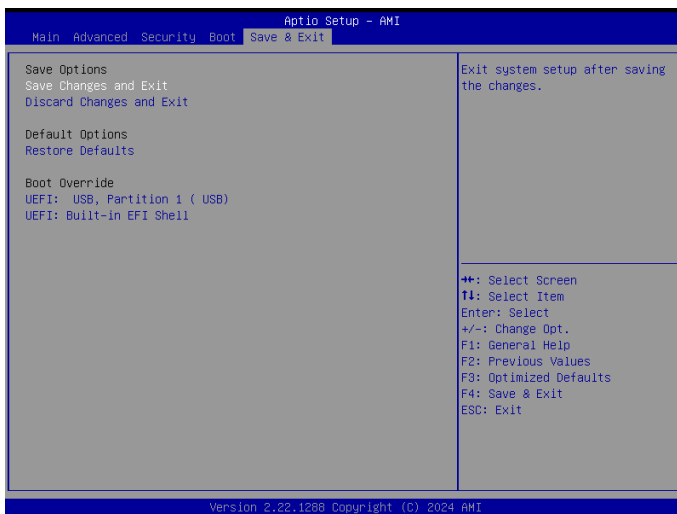

Save Changes and Exit

To save the changes and exit the Setup utility, select this field then press <Enter>. A dialog box will appear. Confirm by selecting Yes. You can also press <F4> to save and exit Setup.

Discard Changes and Exit

To exit the Setup utility without saving the changes, select this field then press <Enter>. You may be prompted to confirm again before exiting. You can also press <ESC> to exit without saving the changes.

Restore Defaults

To restore the BIOS to default settings, select this field then press <Enter>. A dialog box will appear. Confirm by selecting Yes.

Boot Override

To bypass the boot sequence from the Boot Option List and boot from a particular device, select the desired device and press <Enter>.